

# HEISLER

## HL-70 PAIL LABELER



### Superior Features

- Labels stack horizontally.
- No change parts for different size labels.
- Vacuum picks labels.
- Virtually no moving parts to wear because magazine is stationary.
- Labels feed accurately regardless of glue film adjustment.
- Due to the "non-contact design" the glue roller will not be damaged with the label magazine.
- Pails never stop nor turn for label transfer.
- Bail lifting or pre-orientation is not required.
- After the label has been applied to the pail the label is tightly wiped on.
- Patented Technology

### Machine Options

- Right Hand Model or Left Hand Model
- "Baby-in-the-bucket" label sensor, placing it on same side of container every time (U.S.A. Only)
- Synchronized infeed stops
- Spare and wear parts package
- Various colors on request
- PLC Integration
- Pressure Sensitive applicator
- Casters for mobility
- Added conveyor lengths and accessories
- Bar code scanner for proper label detection
- Explosion-Proof package

[www.heislerind.com](http://www.heislerind.com)

### Machine Operation

This machine uses our HLM (Horizontal Label Magazine) to pick, index and feed paper labels. Up to 1000 paper labels are placed flat in a label tray. The label magazine picks up one label at a time, using a series of suction cups, and feeds them into a roller which inverts, or drops, the label onto a label track. The label is now vertical and a feed roller delivers the label to the glue roller, which is coated with water soluble glue. The label with glue then feeds onto two belt stations where the label waits for the pail. Meanwhile, the incoming pail at the infeed on the conveyor is oriented, by two belt stations, for proper positioning of the bail and/or other previously applied labels. The pail now passes through the label gate, where the label is picked up, and continues to a label press-on station, where the label is wiped on. The process is now complete, and the pail with the label exits the machine.

### Machine Features

- High speed operation, up to 30 CPM
- Use of glue that's inexpensive, readily available, and water soluble (for easy cleanup with water)
- All painted and stainless steel construction, making the machine durable and corrosion free for many years of operation
- Machine equipped with only the highest quality pre-manufactured parts available
- Easy to maintain and uncomplicated design throughout allows for ease of basic service and adjustments
- Free life time technical phone support

**HEISLER**  
QUALITY, DURABILITY, SERVICE

*"We are dedicated to the success of your project"*



Denesters • Case/Tray Packers • Lid Placers • Palletizers  
Labelers • Bail-O-Matics • Turn Tables • System Integration

...choice labeling solutions™

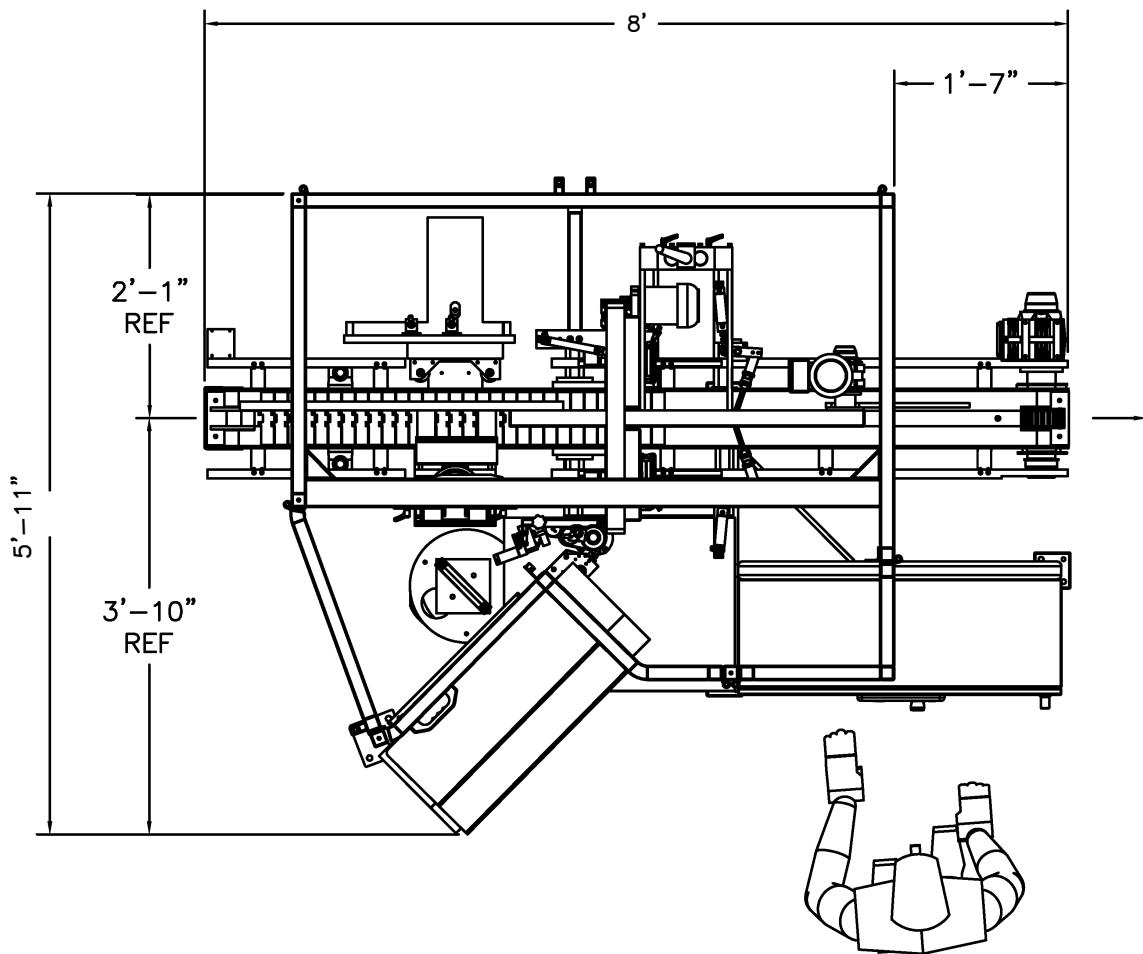

**Technical Specification**

**HL-70 (Standard)**

Container	Straight sided and conical, steel, plastic or fiber
Label height and length	Min height 45, min length 167, max height 228, max length 558 mm
Glueing Process	In horizontal strips covering the whole length of the label
Glue Pump	Pneumatic with service unit and automatic shut-off when machine stops
Compressed Air Connection	90 psi (3-4 bar) 5 cfm
Electric	220/460VAC 3 phase 60 Hz approximately 2 Kw
Speed	Up to 30 CPM / 1800 CPH
Paint	Two part silver metallic epoxy matching stainless steel finish
Weight, net approximately.	2000 lbs. (911 kg.)
Conveyor Measurements	Length: 96" (2438mm) Height: 36" (914mm) +/- 2" (50mm)