

HEISLER

1 GALLON BAIL-O-MATIC - MODEL DS



Machine Operation

Containers are fed along an orienting conveyor into the machine where wire is formed into (bails) handles and attached to the containers simultaneously.

Machine Features

- Interlocked guarding with swing out opening and easy lift off doors allow full access to front of machine. New stationary top guard with extended front doors eliminates the need to remove the top cover for servicing.
- Rear slide compression springs are replaced with new air springs. This eliminates any stored energy potential for operator safety.
- Wire Straightener Assembly with fixed roller configuration now allows for roller replacement in the field.
- Redesigned Cover arm lever to incorporate clamp type connection with keyed shaft, eliminating taper pin.
- Main Plate pocketed for Curling Die Holders. This allows replacement of the pivot bushing hole for the curling die, should they become damaged or worn.
- Main Plate is hard nickel coated.
- Redesigned Clutch Pivot Arm assembly and cylinder eliminates the intermediate linkage and provides improved cylinder life and easier adjustment capabilities
- Front Slide, Rear Slide and Curling dies are fitted to receive lubrication from the oil injection system.
- Escapement arms are equipped with extended rollers to provide added can control.
- Escapement arm pivots are equipped with needle bearings.
- Servo Driven wire feed assembly insures consistent wire length and eliminates the need for the "wire-check" or "anti-backlash" assembly.
- Control panel containing the PLC and Servo control package.
- Operator Interface Panel(Touchscreen)
- Signals provided for upstream and downstream machine interlock control

The HEISLER Bail-O-Matic Model "C" has been a workhorse for over 40 years forming and inserting wire handles on containers. Heisler is now excited to offer a new model of the Bail-O-Matic, the "DS". The Model "DS" offers a mechanical update package addressing safety, wire feed, and mechanical components. In addition a complete control package and servo driven wire feed system are included.

"The Bailer", as it is commonly known, is designed to automatically form and insert handles (bails) onto metal or plastic containers at an average speed of 50 per minute. Different machines are available to handle containers ranging from 1 to 7 gallon.

Designed and built in the USA, the machine is made to exacting standards for continuous use under various conditions.

Machine Options

- **Accessory Chain** permits pints and quarts to pass through the machine.
- **Reject Unit** Removes cans from the line if their bails are not properly attached.
- **Bail Knockdown** Places the bail along wall of can.
- **Bail Hold up kit**
- **Spare parts and Maintenance kit**

www.heislerind.com

HEISLER
QUALITY, DURABILITY, SERVICE

"We are dedicated to the success of your project"



Denesters • Case/Tray Packers • Lid Placers • Palletizers
Labelers • Bail-O-Matics • TurnTables • System Integration

...choice labeling solutions™

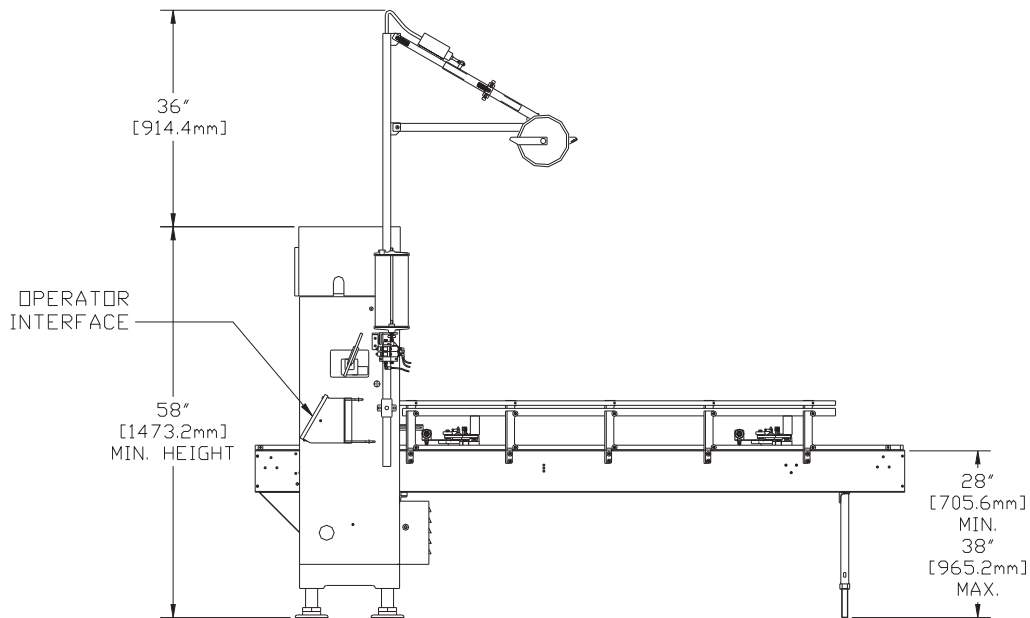
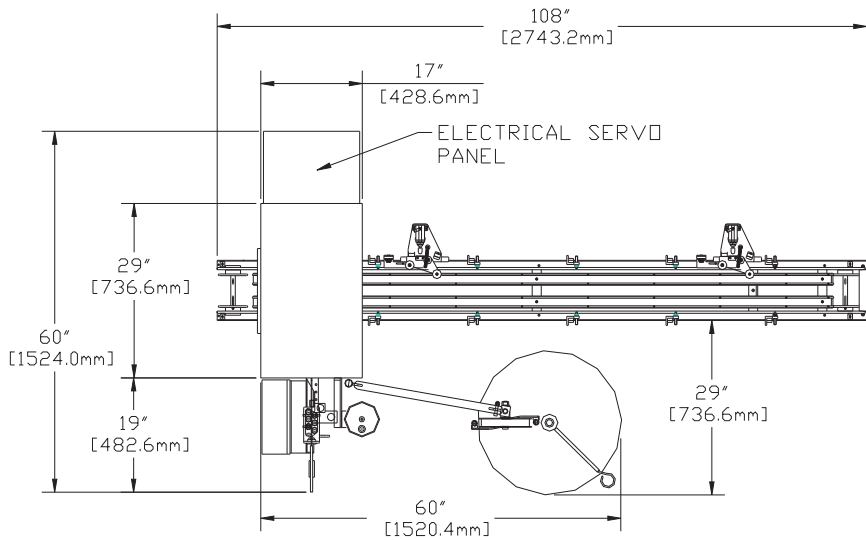

Technical Specification	1 Gallon Bailer – Model DS
Speed	55 Cans/Min.
Controls	Allen Bradley SLC 5/03 PLC
HMI	6" TCP Quickpanel Jr.
Electrical	220/440 VAC, 3 Phase, 60 Hertz
Air	5 CFM @ 80 PSI
Wire	1 Gallon – Standard 12 gauge (.1055 +/- .003)
Floor Space	36 Square Feet
Shipping Weight	2,300 Lbs

HEISLER
QUALITY, DURABILITY, SERVICE

224 Passaic Ave, Fairfield, NJ
TEL 973-227-6300 • FAX 973-227-7627
www.heislerind.com